



## GENERAL INFORMATION ABOUT ASYNCHRONOUS MACHINES

Komiljonov Jasurbek O'ktamjon o'g'li

Trainee teacher of Andijan Institute of Agriculture and Agrotechnology

E-mail: jkomiljonov444@gmail.com

Tel: +998 88 272 28 94

Abdulatipov Oyatillo Alisher o'g'li

Student of Andijan Institute of Agriculture and Agrotechnology

E-mail: oyatilloabdulatipov@mail.ru

Tel: +998 93 252 83 23

### ABSTRACT

This article provides general information about asynchronous motors, the principle of operation, the advantages and disadvantages of the structure types. Asynchronous machines are designed to work in sinusoidal alternating current. The principle of their operation is based on the formation of a rotating magnetic field when a three-phase current passes through three coils. Currently, three-phase alternating current asynchronous machines are widely used.

**Keywords:** motor, collector, shaft, rotor, stator, phase, asynchronous, current, voltage, coil, plate.

### **The main types of alternating current electric machines.**

Asynchronous machines are designed to work in sinusoidal alternating current. The principle of their operation is based on the formation of a rotating magnetic field when a three-phase current passes through three coils. Currently, three-phase alternating current asynchronous machines are widely used. Asynchronous machines are divided into three groups: a) asynchronous machines without a collector; b) collector asynchronous machines.

Asynchronous machines mainly consist of two parts: the stationary part - the stator; rotating part - rotor.

There is an air gap between the stator and the rotor. This interval is relatively large in synchronous machines, small (for example, 0.2...3 mm) in asynchronous machines. In asynchronous and synchronous machines, the structure of the stator is almost the same; but their rotors are different in structure. In practice, single and three-phase asynchronous and synchronous machines are widely used. Three coils in the stator of three-phase machines; single-phase machines have one coil.





In asynchronous machines, the rotation frequency of the rotor is not equal to the rotation frequency of the rotating magnetic field, that is, they do not rotate synchronously. Such machines are called asynchronous machines.

Asynchronous machines are mainly used as motors. Millions of asynchronous motors drive various mechanisms in various sectors of the economy. In general, synchronous and asynchronous machines can work both as generators and as motors. In addition, synchronous machines as synchronous compensators; and asynchronous machines are used as electromagnetic brakes and frequency converters.

Even in alternating current collector machines, the rotor does not rotate at the same speed as the rotating magnetic field, and in this respect they are asynchronous machines. But since such cars have a collector, they form a separate group. Collector cars have more engines

is used as Their principle of operation is close to the principle of operation of DC machines. AC collector machines are rarely used in practice.

The ferromagnetic core (magnetic conductor) and coils of electric machines are its main active parts. The rest are structural parts that ensure the rigidity, strength, rotation and cooling of the machine (Fig. 11.1).

In asynchronous and machines, the structure of the stator is the same. The stator of such machines consists of its case (frame), base, bearing caps that cover the case in two, and a steel core assembled from special thin electrotechnical steel plates inside the case of the stator. The steel core wedges, offset by  $120^\circ$  relative to each other in space, have three shafts. The stator of single-phase machines has one coil.

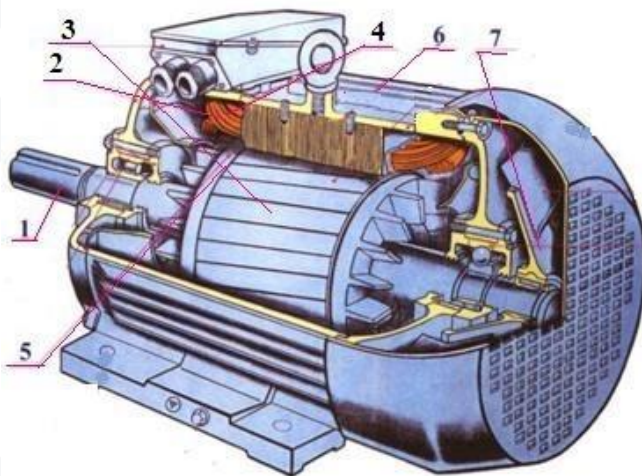

- 1-shaft
- 2-stator winding
- 3-rotor winding
- 4-stator core
- 5-stator core
- 6-corps
- 7-fan

Figure 11.1. The structural structure of the asychron machine



The structure and principle of operation of asynchronous machines.

In electric machines, the steel core is assembled from a special thin sheet of electrical engineering steel. The steel cores of the stator and rotor contain 1...3% silicon. The thickness of steel sheets is 0.3 ... 0.5 mm. After the steel core is assembled, it is pressed into the frame. The stator frame can be made of aluminum or cast iron. In asynchronous machines, the steel core of the rotor is assembled from special steel sheets and fixed by pressing to the shaft (axle) or rotor bushing. In micromachines, steel cores are assembled from iron-nickel alloy plates.

Asynchronous machines according to the structure of the rotor:  
with a short-circuited rotor, Fig. 11.2.

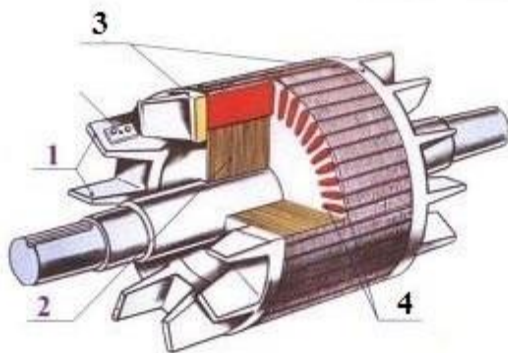

Short-circuited rotor.

- 1-ventilation flaps;
- 2-magnetic conductor of the rotor;
- 3-short circuit ring;

Figure 11.2. Asynchronous machine's coiled rotor.

The core of the rotor is assembled from electrotechnical steel tunics, and the outer side consists of a wedge-forming cylinder. In order to reduce the loss of power generated by accumulated currents, both sides of each steel tunic forming the rotor core are covered with insulating varnish.

Aluminum or copper rods (sticks) are placed in the rotor core of the short-circuited rotor motor, and their ends and ends are made of aluminum or copper. Brush holders with brushes

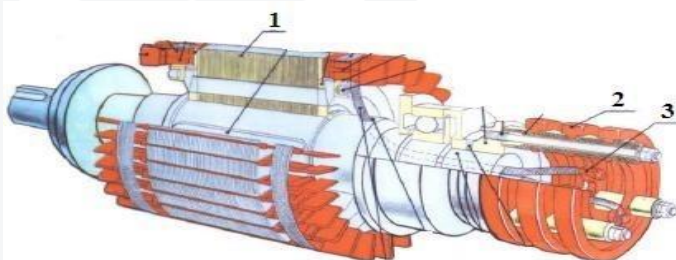

**Brush holders with brushes**

- stator winding
- 2- contact rings
- 3- connection to contact rings
- 4- brushes
- 5- brushes handles
- 6- power cable

Figure 11.3. Phase (contact ring) rotor of an asynchronous machine.



Phase (contact ring) is divided into rotor motors (Fig. 11.3).

A three-phase coil is installed on the rotor core of a phase-rotor motor, like the stator. In order to reduce the starting current of the motor, a series external resistance is introduced into the rotor winding circuit.

The rotor coil is connected in a "star" scheme, and three mutual and shaft-insulated rings are installed on the rotating rotor shaft (axis) to introduce external resistance to each of its phases. The ends of the phase winding in the rotor are connected to three rings, and the rings are connected to the starting resistor through fixed brushes (Fig. 11.4).

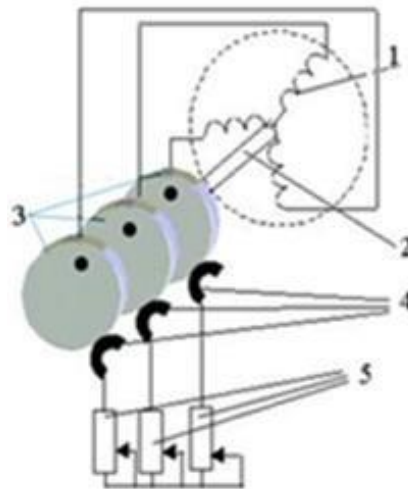
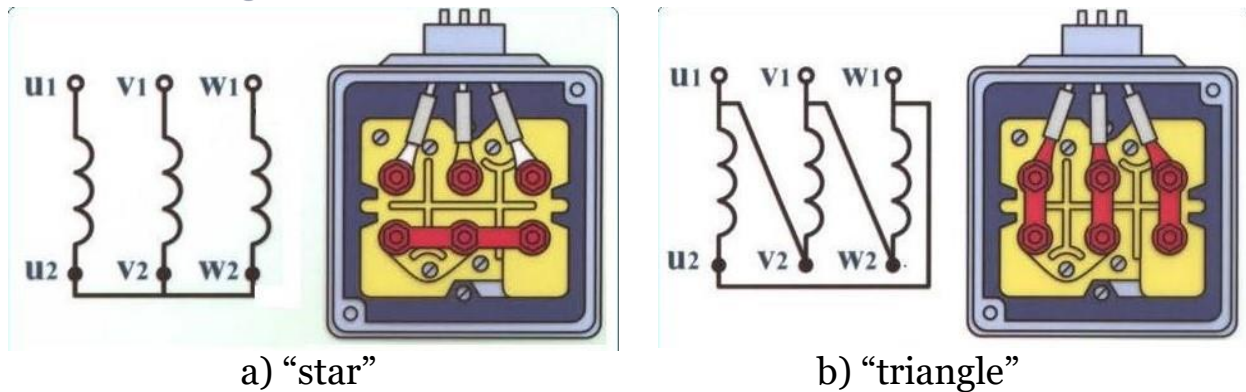

Figure 11.4. Connection of an adjuster rheostat to a phase rotor motor.

In large-power asynchronous electric motors and small-power special machines phase rotors are used to improve their start-up and adjustment characteristics. In this case, the three-phase rotor coils (1) are connected to the contact rings (3) installed on the shaft (axis) (2). In turn, the adjuster is connected to the rheostats (5) with the help of brushes (4) touching these rings.

The structure of the three-phase winding placed on the stator of asynchronous machines does not differ from the winding of a synchronous machine. The ends of the stator windings are connected to the parts on the engine block. In this case, the first phase circuit is determined by C1-C4, the second by C2-C5, and the third by C3-C6. To connect the coil with a "star" scheme, the ends are attached to the parts of the motor shield as shown in Fig. 11.5, a. Fig.



11.5 b shows the connection of the ends of the coils in the motor box with "triangle" schemes.

11.5 - picture. Methods of connecting the stator windings of asynchronous machines  
When a three-phase current is supplied to the stator winding of an asynchronous motor.

A rotating magnetic field with a frequency of  $n_1 = 60 f / p$  is created. The rotating magnetic field crosses the rotor winding and creates an EMF in its closed-circuit winding. As a result of the interaction between the current in the rotor coil and the rotating magnetic field in the stator, a rotating electromagnetic moment is created, as a result of which the motor starts to rotate with a frequency of  $n_2$ . The direction of the torque-generating forces is determined by the left-hand rule.

The electrical energy supplied to the stator of the motor is converted into mechanical energy that rotates in the rotor as a result of the electromagnetic process. To change the direction of rotation of an asynchronous motor, it is enough to interchange any two ends of the stator winding that are connected to the electrical network. In this case, the directions of rotation of the rotating magnetic field and the rotor rotating towards it are reversed. The synchronous frequency of the rotating magnetic field  $n_1$  of the rotor is always small compared to  $n_1$ . If  $n_2 = n_1$ , current and torque are not generated in the rotor coil. The ratio of the difference between the rotating magnetic field and the rotor frequency to the synchronous frequency is called slip and is denoted by the letter  $S$ . So, the value of the slip is expressed as:

$$S = (n_1 - n_2) / n_1$$

### Conclusion

The advantages of asynchronous motor over synchronous motor are low price, simple structure, asynchronous motor is used in many fields, asynchronous motor is divided into two types: 1) phase rotor 2) short circuit rotor motors.



## References

1. J.S.Salimov, N.B.Pinnatov "Electric machines" Tashkent, o Publishing house of the Society of Philosophers of Uzbekistan, 2011.
2. S.Majidov "The term electrical engineering is Russian-Uzbek dictionary", o teacher publishing house, 1992 and 1998.
- 3.S.Majidov, Electric machines and electric drive. Profession for agricultural electrification specialties of colleges textbook. - T.: o teacher, 2002. ~ 358 p.
- 4.N.M.Aripov. "Automated electrical management" Fergana, 2001 y385 www.ziyouz.com library
- 5.U.T.Berdiev "Electric equipment of hydromelioration machinery use" "Vorish-nashriyot" Tashkent-2007y
- 6.Salimov J.S, Pirmatov N.B., Bekchanov B.E. "Transformers and auto-transformers." Training for technical universities not available. - T.: "Vector press", 2009.
7. Hoshimov O.O., Imomnazarov A.T. Basics of electricity. 1- part. "Electrical engineering, electromechanics and study guide for students of "electrotechnologies". - Tashkent, TDTU, 2004. – 194.

