

PROSPECTS FOR THE DEVELOPMENT OF A MODERN PNEUMATIC DRYER OF SOLAR RADIATION TYPE AND THE PRINCIPLE OF ITS OPERATION

U. Qayumov

Assistant of Andijan Machine-Building Institute

ANNOTATION

The article covers the experimental and theoretical studies, as well as the analysis of the use of pneumatic structures in rural areas and other sectors of the economy, and information on the principle of converting solar radiation into heat energy.

Keywords: analysis, pneumatic structures, rural areas, sectors of the economy, real-life drying, thermal energy, double-layer pneumatic structure, electric heater and etc.

INTRODUCTION

The experimental and theoretical studies carried out, as well as the analysis of the use of pneumatic structures in rural areas and other areas of the national economy, allow us to proceed to the task of substantiating, developing and manufacturing a real-life drying plant operating on the principle of converting solar radiation into thermal energy. At the same time, the dryer must function for its intended purpose and be used as an overlapping ceiling in bad weather.

Taking into account these requirements, we have proposed a pneumatic two-layer structure with extended functionality, shown in Fig. 3.1 and 3.2.

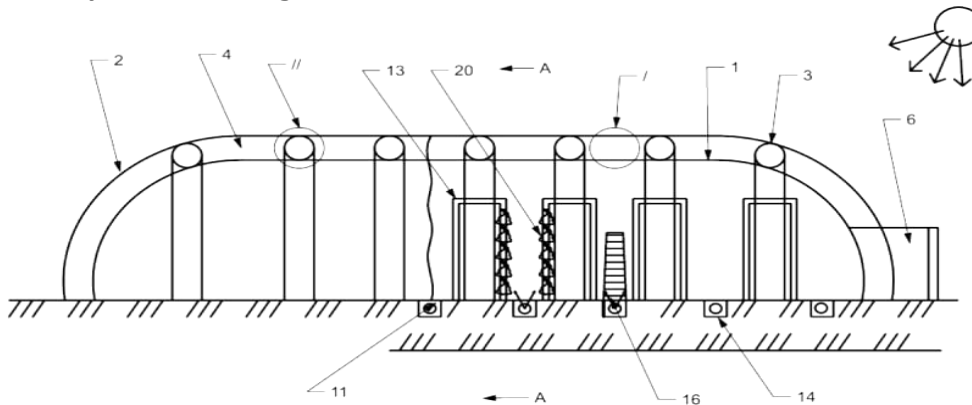

Fig.3.1. Double-layer pneumatic structure as a solar-radiation drying plant for drying grapes

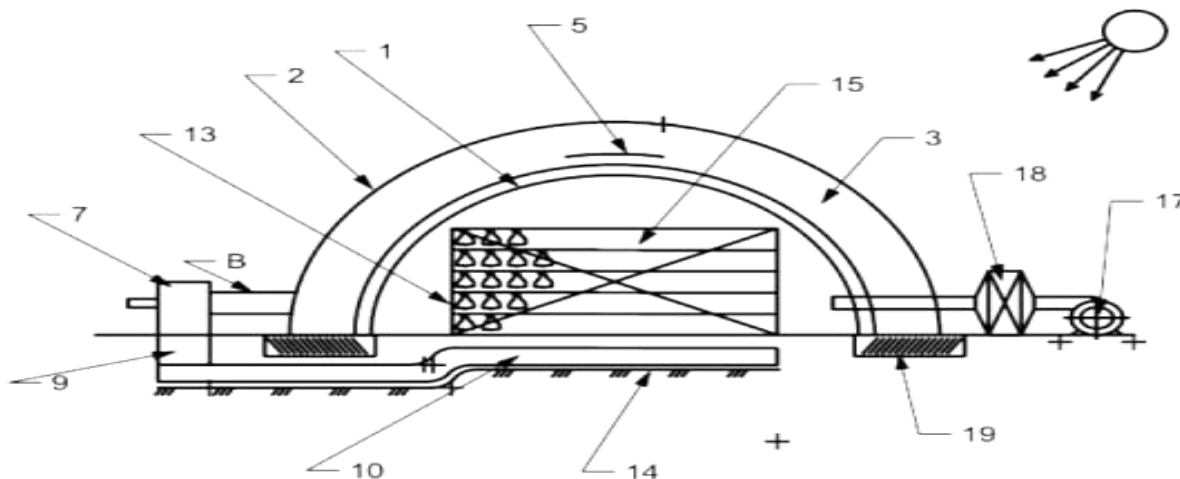

Fig. 3.2. Cross section of pneumatic dryer

The proposed air-supported drying plant contains an inner main shell 1 and an outer translucent shell 2, between which pneumatic arches 3 are placed, forming an intershell space 4.

The inner shell is made of reinforced dacron with a blackened neoprene coating, with solar radiation absorption capacity $n=0.52-0.6$, and the outer shell is made of chlorosulfonated polyethylene (Hypolon).

On the roof of the inner shell 1 there are at least two flexible valves 5, two air passages from the subshell space to the intershell space. From the end part of the air-supported structure there is a sealed lock 6 for the entrance of service personnel and carts with the product to be dried (not shown in the figure). On the side of the structure is a fan 7; the suction pipe 8 which is connected to the intershell space 4; and the discharge pipe 9 communicates with the air distribution manifold 10, the sleeves 11 of which are placed in the form of a comb, while drainage holes 12 are made on them, located at an angle of 90-1200 relative to each other and directed towards the drying racks 13. In order to avoid damage to the sleeves, they are placed in concrete trays 14. For the convenience of hanging bunches of grapes on hanger 15, a mobile household ladder 16 is provided. In case of operation of the drying plant at night and in rainy weather (late autumn), the structure is equipped with an additional fan 17 and an electric heater 18. Pneumatic air-supported dryer is mounted on strip foundation 19.

Before starting the operation of the drying plant, a pneumatic structure is mounted. To do this, the inner main shell 1, the pneumatic arches 3 and the outer shell 2 are fixed on the prepared strip foundation 19 (they can be made together into one assembly unit at the Angren Rezanotekhnika plant and delivered to the assembly site).

After installation, the fan 17 and the electric heater 18 are turned on and warm air is supplied under the inner shell 1, which softens under the influence of air, folds and acquires a working semi-cylindrical shape. Upon reaching the calculated overpressure under it, the air flows through the flexible valve 5 into the intershell space 4 and brings the outer shell 2 into working position. working position.

Then a hermetic gateway 6 is installed and drying racks 13, a mobile ladder 16 and sleeves 11 are brought inside the structure through it. After their pre-assembly and installation, the suction pipe 8 of the fan 7 is connected to the inter-shell space 4, and the discharge pipe 9 is connected to the air distribution manifold 10.

Air dryer works as follows. Commodity drying grapes of kishmish varieties, for example, "Sogdiana", "Kara Botir", "Zarafshan", etc. are brought through the gateway 6 inside the pneumatic structure. Here, on non-layout tables, individual brushes are combined into larger brushes 20 and hung on hangers 15 located on both sides of the drying racks 13. The air supplied by the fan 17 is heated in the electric heater 18 and enters the subshell space and, rising up, passes through the flexible valve 5 into the intershell space 4. The fan 7 draws in warm air and, through the discharge pipe 9 and the air distribution manifold 10, delivers it to individual sleeves 11, through the holes 12 of which the hanging brushes 20 of the wine are blown with air. In a stream of warm air, the grapes are dried by analogy with the "soyaki" method.

In sunny clear weather, the dryer can work with the electric heater 18 turned off.

At the same time, the Sun's rays with an intensity of $q \approx 900-1200 \text{ W / m}^2$ translucent shell 2 and, in turn, heats the air in the inter-shell space 4. In good sunny weather, the air warms up to a temperature of 55-60 ° C, which allows the drying process to be carried out with active ventilation.

Thus, for an electromental drying plant with the dimensions of a pneumatic structure of 18x6 m, the surface of the heat-absorbing roof is about $F = 3200 \text{ m}^2$. Taking on average for the city of Tashkent the

intensity of solar radiation $q = 940 \text{ W/m}^2$ and the duration of insolation 8 hours, it is possible to obtain more than 2400 kW of energy, which naturally gives significant savings.

The only requirement for the operation of such drying plants is the installation of the structure in the east-west direction.

Pneumatic construction-dryer is quickly erected, transportable and can be operated in any bad weather.

LITERATURE

1. Исмаилова А.А Исследование тепловых процессов солнечных фруктосушилках различной конструкции. Дис .канд. тех. Наук. М 1957-187с
2. Артыков С., Максудов С. Гелиос гелиосушилка фобака// Гелиосушилка – 1988 №1 С.27-29
3. Ахмадалиев А. Результаты испытания опытно - промышленной солнечной фруктов сушильной установки //Гелиотехника 1974 №2 С.71-73
4. Таиров З. Повышение эффективности гелиосконвективной сушки плодов и винограда Дис. канд. тех. наук Ашхабад 1986
5. Фахрединова Э. М Разработка и следование солнечных установок для сушки сельскохозяйственной продукции. Автореф дис. дисс . канд. тех. наук Ашхабад 1984-18с
6. Khadjiyeva Salima Sadiqovna, Ibragimjanov Bakrambek Hamidovich Some Recommendations for the Application of Powder Alloys in the Restoration of Agricultural Machinery Parts by Plasma Surface and Spraying Methods <https://journals.researchparks.org/index.php/IJOT/article/view/3138>
7. Yusupova Ranakhon Kasimdjanovna Analysis of IP Sustainability and Efficiency Coefficiency <https://cejsr.academicjournal.io/index.php/journal/article/view/1228>.